



1 Quai du Président Wilson,  
33130 Bordeaux, Francia  
Tel. +33 5 56 20 59 89  
commercial.france@vidrala.com

# BG EVOLUTION 75 CL BVS

## Product characteristics

<b>Code</b>	4691/477
<b>Capacity</b>	750 ml
<b>Colours</b>	
<b>Weight</b>	440 gr
<b>Overall height</b>	295.00 mm
<b>Diameter</b>	81.20 mm
<b>Palet</b>	1.358 units



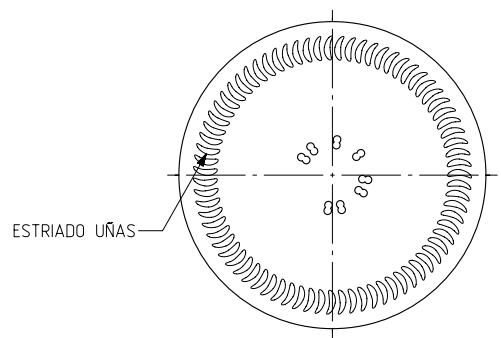
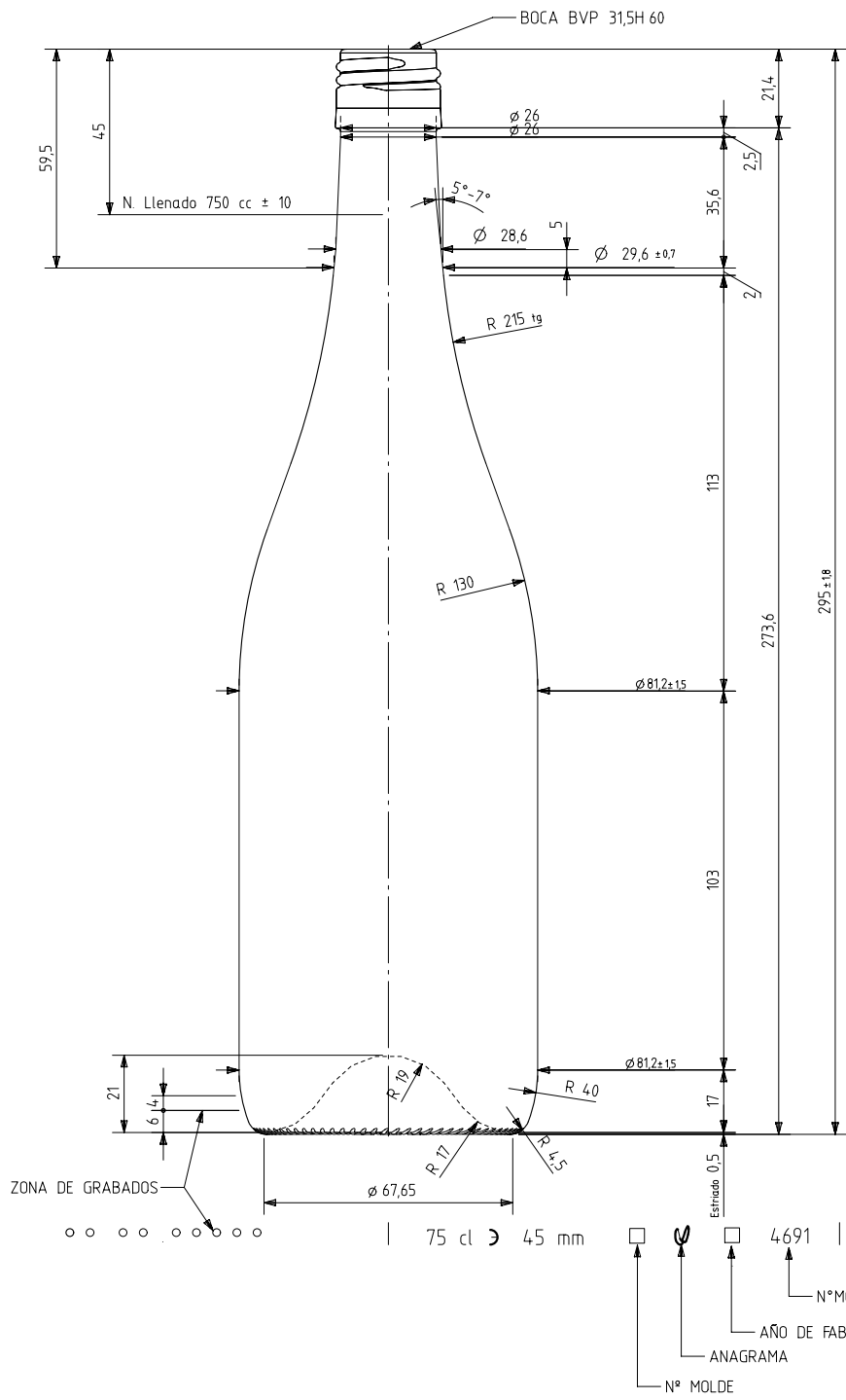

VISTA DEL FONDO

			Peso aprox / Weight approx	440 gr
			Capacidad N. llenado / Fillpoint Capacity	750 cc ± 10 a 45,0 mm
			Capacidad a verter / Brimfull Capacity	764,0 cc ± aprox
3	Se cambia codigo de Boca de 476	26-08-13	JAU	Cámara expansión / Expansion Chamber
2	Modif. grabados del fondo al talon	21-11-11	JAU	Recipiente medida / Meas cap
1	Modif. cuello s/norma 476	07-05-10	JAU	Angulo de volcado / Tilt angle
Rev	Modificación / Modification	Fecha/Date	Firma/Sign	Carbonatación / Gas vol
Este plano es propiedad de Vidrala, no puede ser reproducido ni comunicado sin nuestro permiso. Las cotas no toleradas son aproximadas. Specification agreements are based on toleranced dimensions only. Do not scale drawing, copyright reserved. Not to be copied in whole or part without written permission from Vidrala. All dimensions are in millimeters.				Presión inf. max. (20°) / Max Pressure (20°)
				0,00 Bar
				Resistencia. choque térmico / Thermal Shock Max:
				42 °C

		Product Design Office www.vidrala.com	
		Dibujado / Des : A. Molano	CAD: 9691-3prt
Fecha / Date: 20-11-08		Anula / Annuls: 9691-2	
Escala / Escala: 1/1		Nº Plano: 9691-3	
Retornable / Refillable: NO		Drawing Nº: 61,6%	
Modelo: Code: 4691/477		BOURGOGNE EVOLUTION 75CL. BVS	