

## 8 PAR LITE

### Caractéristiques du produit

<b>Code</b>	2248/504
<b>Capacité</b>	244 ml
<b>Bague</b>	TWIST OFF 53
<b>Couleurs</b>	
<b>Poids</b>	145 gr
<b>Hauteur totale</b>	127.00 mm
<b>Diamètre</b>	57.50 mm
<b>Palette</b>	5.600 Unités



VISTA TRASERA  
(BACK VIEW)

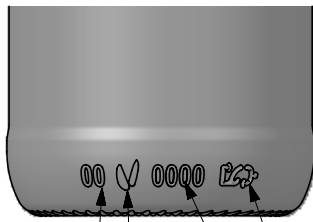

N° MOLDE  
(CAVITY NUMBER)

Logo FEVE

ANAGRAMA  
(PUNTMARK VIDRALA)

N° MODELO  
(JOB No)

VISTA FRONTAL  
(FRONT VIEW)

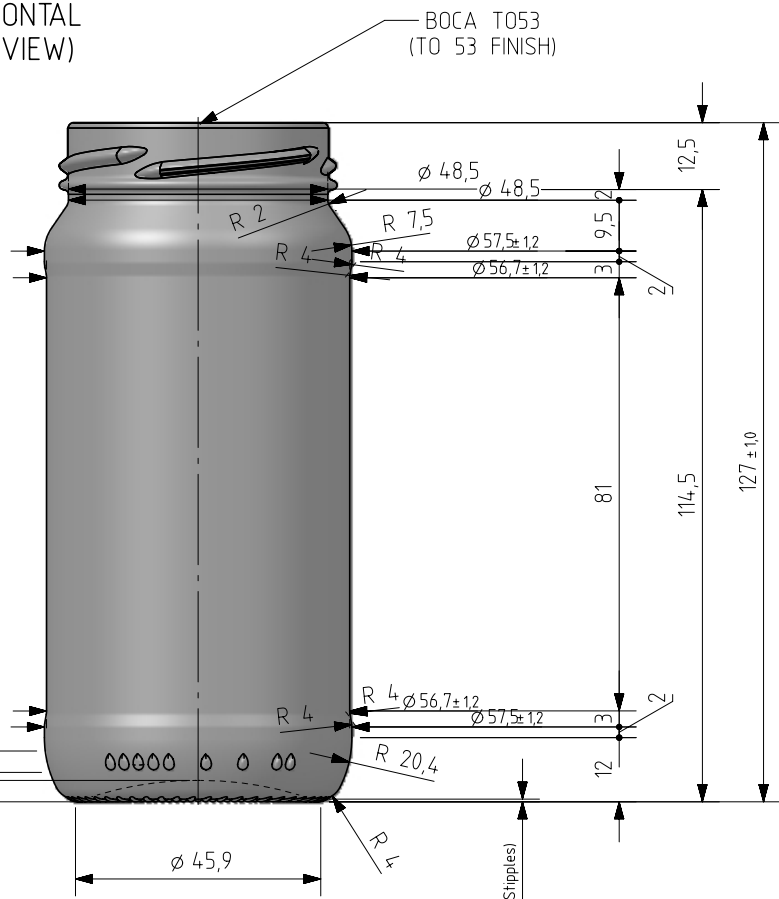

ZONA DE GRABADOS / HEEL EMBOSING  
(Opuesto al código de pts / Opposite to dot code)

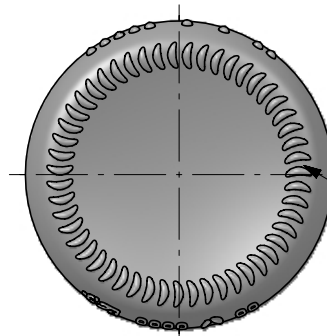

ESTRIADO UÑAS  
(STIPLING)

VISTA DEL FONDO  
(BOTTOM VIEW)

Este plano es propiedad de Vidrala, no puede ser reproducido ni comunicado sin nuestro permiso.

Las cotas no toleradas son aproximadas.

Specification agreements are based on toleranced dimensions only. Do not make drawing copyright

Not to be copied in whole or part without written permission from VIDRALA

All dimensions are in millimeters

Rev	Modificación / Modification	Fecha/Date	Firma/Sign
Peso aprox / Weight approx		145	g
Capacidad N. llenado / Fillpoint Capacity		244 ml±	aprox a 0 mm
Capacidad a verter / Brimfull Capacity		244 ml±	aprox
Cámara expansión / Vacuity		,0	% 0 ml
Recipiente medida / Meas cap		NO	
Angulo de volcado / Tilt angle		26,5°	
Carbonatación / Gas vol		0,0	Vol.CO2 max
Presión larga duración/Long term pressure:		0,00	Bar max Páster SI
Resistencia. choque térmico / Thermal Shock max:		42 °C	

Rev	Modificación / Modification	Fecha/Date	Firma/Sign
		Product Design Office www.vidrala.com	
		Dibujado / Des : J. OCHOA	CAD: 7963.prt
Fecha / Date. 29-05-23		Anula / Annuls: -	
Escala / Scale: 1:1		N° Plano: Drawing N°: 7963	
Retornable / Refillable NO		70,0%	
Modelo: Code: 2248/504		8 PAR LITE	