

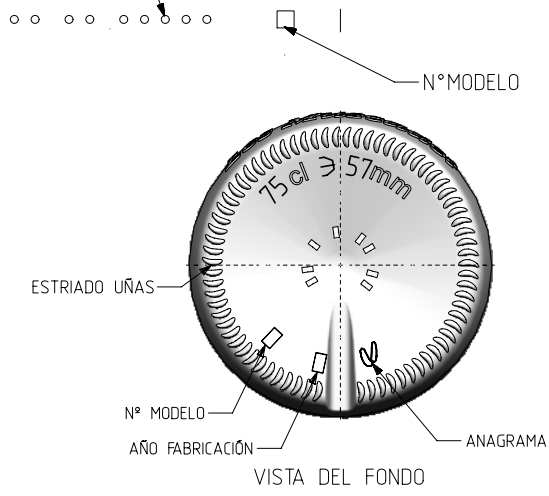

# MUSCADET SUR LIE NATURA 75 CL

## Caractéristiques du produit

<b>Code</b>	2033/242
<b>Capacité</b>	750 ml
<b>Bague</b>	CORCHO CETIE
<b>Couleurs</b>	
<b>Poids</b>	470 gr
<b>Hauteur totale</b>	322.00 mm
<b>Diamètre</b>	80.10 mm
<b>Palette</b>	1.206 Unités

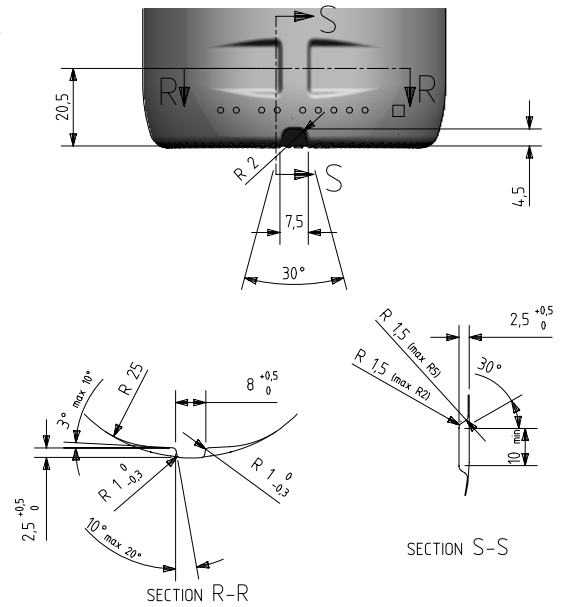
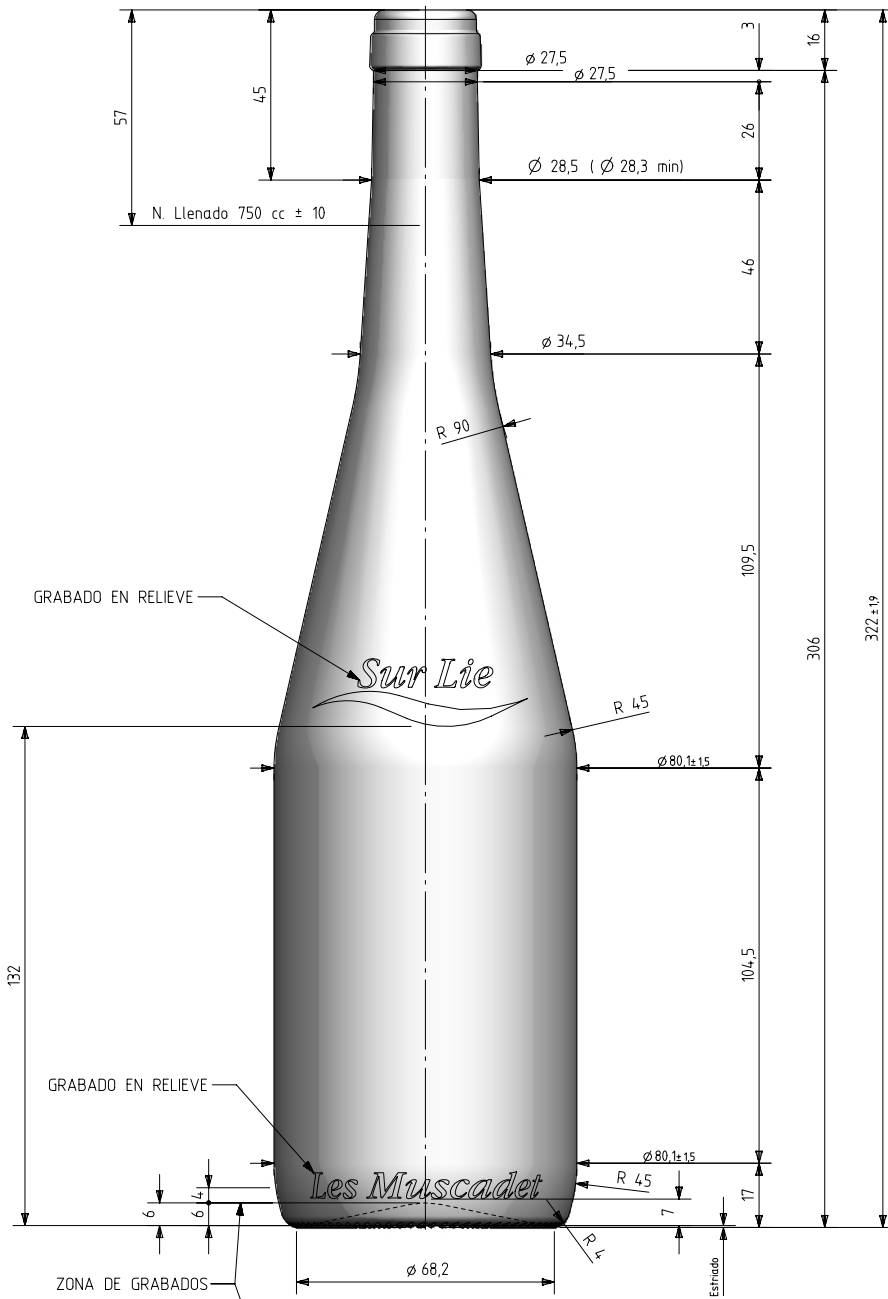



			Peso aprox / Weight approx	470 gr	 Product Design Office www.vidrala.com	
			Capacidad N. llenado / Fillpoint Capacity	750 cc ± 10 a 57,0 mm		
			Capacidad a verter / Brimfull Capacity	768,0 cc ± aprox	Dibujado / Des : J. Ochoa CAD: 7233prt	
			Cámara expansión / Expansion Chamber	2,4 %	Fecha / Date: 13-03-14 Anula / Annuls:	
			Recipiente medida / Meas cap	SI	Escala / Escala: 1:1 N° Plano: 7233	
			Angulo de volcado / Tilt angle	17,2°	Retornable / Refillable NO N° Plano: 62,1%	
Rev	Modificación / Modification	Fecha/Date	Firma/Sign	Carbonatación / Gas vol	0,0 Vol CO2 máx	Modelo: 7233
Este plano es propiedad de Vidrala, no puede ser reproducido ni comunicado sin nuestro permiso. Las cotas no toleradas son aproximadas. Specification agreements are based on toleranced dimensions only. Do not scale drawing, copyright reserved. Not to be copied in whole or part without written permission from Vidrala. All dimensions are in millimeters.				Presión inf. max. (20°) / Max Pressure (20°):	0,00 Bar	Code: 2033/242
				Resistencia. choque térmico / Thermal Shock Max:	42 °C	MUSCADET SUR LIE NATURA 75 CL