

VAL DE LOIRE NATURA 75 CL

Product characteristics

Code	2085/242
Capacity	750 ml
Finish	CETIE
Colours	
Weight	455 gr
Overall height	309.50 mm
Diameter	81.20 mm
Palet	1.164 units

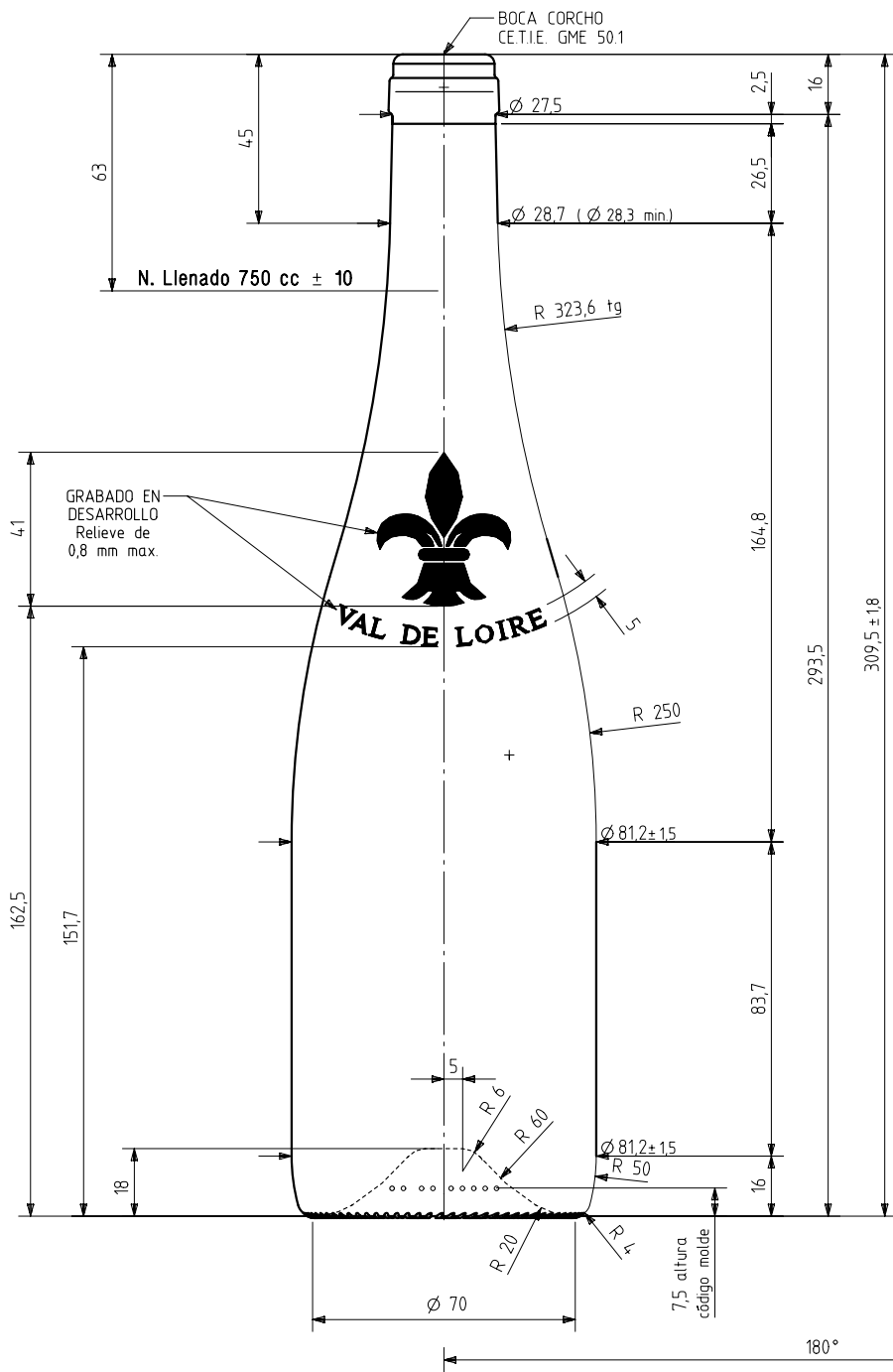



NOTA: Inscripción y posicionador lateral y de fondo en la cara opuesta al grabado en relieve y código molde

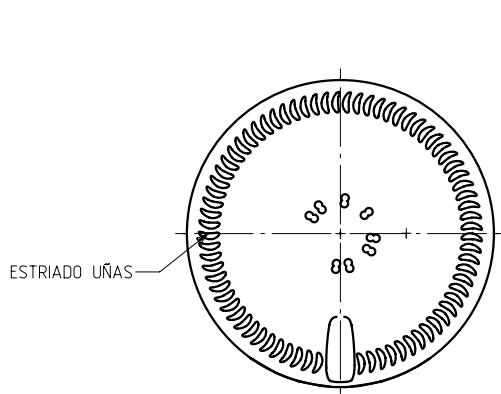
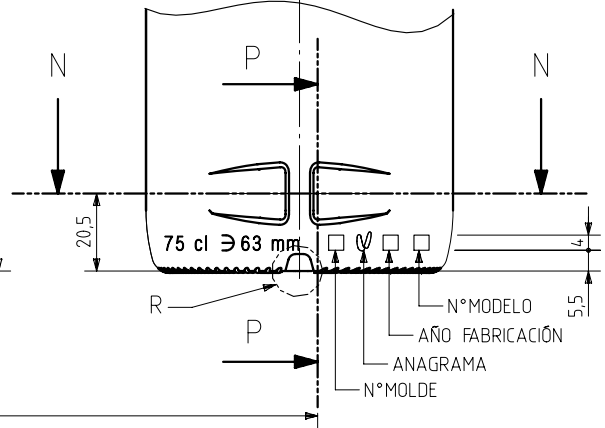

VISTA DEL FONDO

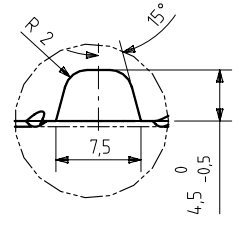

DETALLE R Escala 3:1

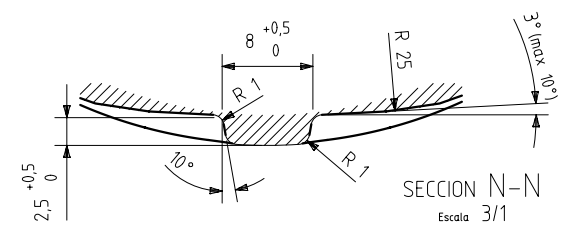

SECCION N-N Escala 3/1

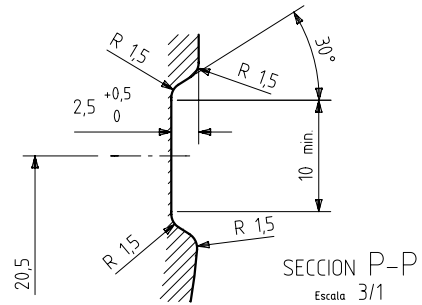

SECCION P-P Escala 3/1

			Peso aprox / Weight approx	455 gr	 Product Design Office www.vidrala.com		
			Capacidad N. llenado / Fillpoint Capacity	750 cc ± 10 a 63,0 mm			
			Capacidad a verter / Brimfull Capacity	770,0 cc ± aprox			
			Cámara expansión / Expansion Chamber	2,7 %			
			Recipiente medida / Meas cap	SI	Dibujado / Des. : ALR	CAD: 8422-1prt	
			Angulo de volcado / Tilt angle	18,5°	Fecha / Date: 20-02-13	Anula / Annuls: 8422	
1	Cambio Denominación	17-02-14	JAU	Carbonatación / Gas vol	0,0 Vol CO2 máx	Escala / Escala: 1/1	N° Plano: 8422-1
Rev	Modificación / Modification	Fecha/Date	Firma/Sign	Presión inf. max. (20°) / Max Pressure (20°):	<input checked="" type="checkbox"/> Bar	Retornable / Refillable NO	Drawing N°: 57,8%
Este plano es propiedad de Vidrala, no puede ser reproducido ni comunicado sin nuestro permiso. Las cotas no toleradas son aproximadas. Especification agreements are based on toleranced dimensions only. Do not scale drawing, copyright reserved. Not to be copied in whole or part without written permission from Vidrala. All dimensions are in millimeters.				Resistencia. choque térmico / Thermal Shock Max:	42 °C	Modelo: Code: 2085/242	VAL DE LOIRE NATURA 75 cl