

# 12 PAR

## Product characteristics

<b>Code</b>	1277/085
<b>Capacity</b>	358 ml
<b>Colours</b>	
<b>Weight</b>	210 gr
<b>Overall height</b>	153.00 mm
<b>Diameter</b>	62.30 mm
<b>Palet</b>	3.996 units

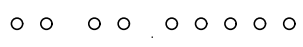

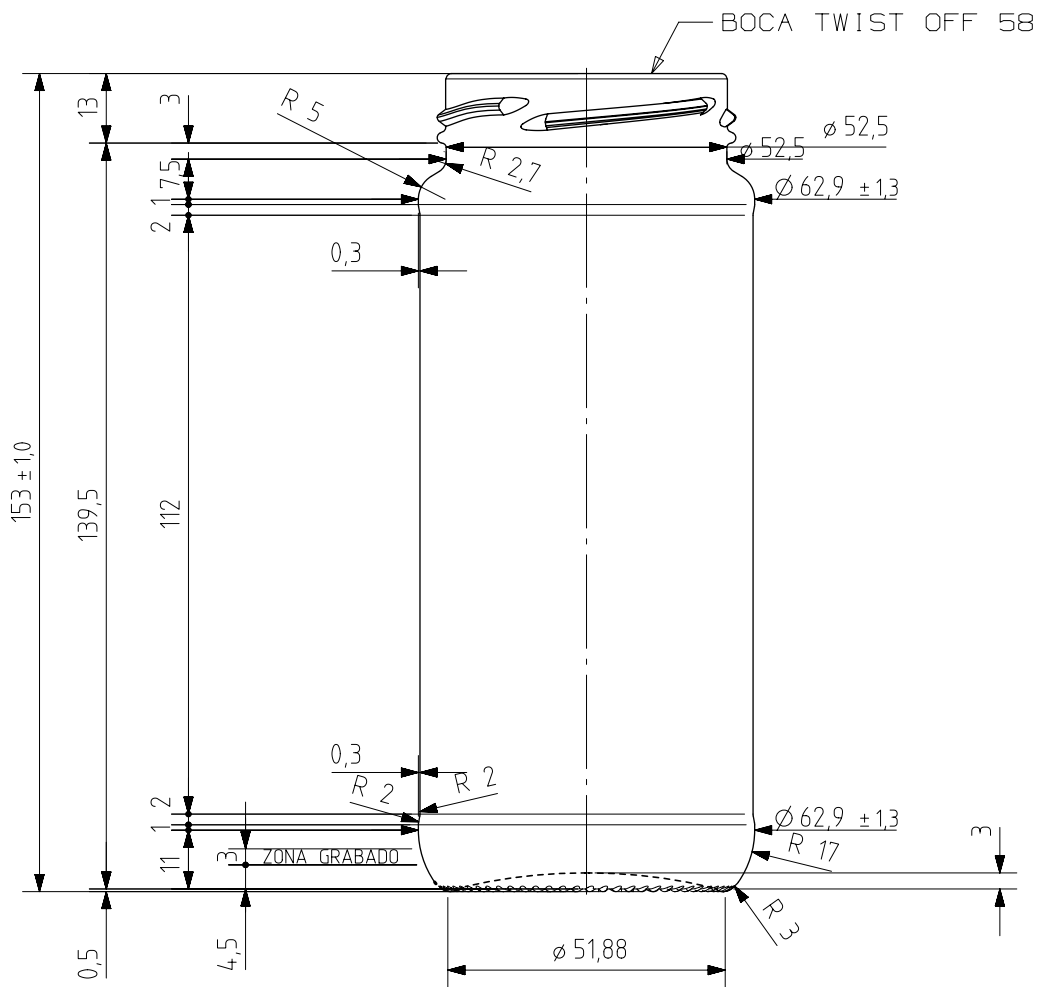

N° MOLDE

ANAGRAMA

N° MODELO

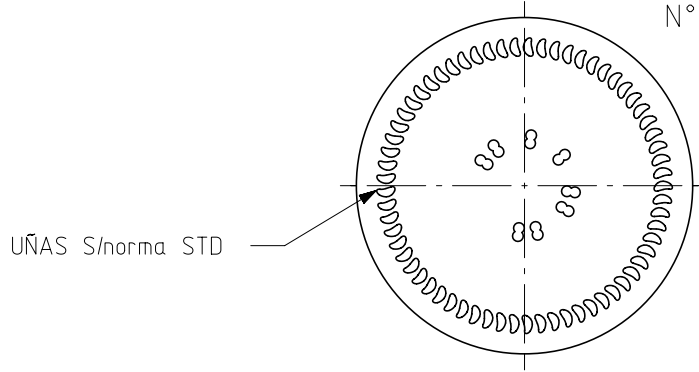

VISTA DEL FONDO



<p>Este plano es propiedad de Vidrala, no puede ser reproducido ni comunicado sin nuestro permiso.          Las cotas no toleradas son aproximadas.          Specification agreements are based on tolerance dimensions only. Do not scale drawing copyright.          Not to be copied in whole or part without written permission from VIDRALA.          All dimensions are in millimeters.</p>	3	Renombrada boca 521 como 085	21-11-17	JAU				
	2	Se corrige tolerancia de altura.	19/01/15	AMC				
	1	Peso 210 gr. (antes 215)	7-01-09	ALR				
	Rev	Modificación / Modification	Fecha/Date	Firma/Sign	Rev	Modificación / Modification	Fecha/Date	Firma/Sign
	Peso aprox / Weight approx		210 gr					
	Capacidad N. llenado / Fillpoint Capacity		0 cc± a ,0 mm					
	Capacidad a verter / Brimfull Capacity		358,0 cc± 7					
	Cámara expansión / Vacuity		4,6 %	0 cc				
	Recipiente medida / Meas cap		NO					
	Angulo de volcado / Tilt angle		22,7 °					
Carbonatación / Gas vol		0,0 Vol.CO2 máx						
Presión larga duración/Long term pressure:		0,00 Bar Max	Páster	NO				
Resistencia choque térmico / Thermal Shock Max:		42 °C						
						Product Design Office www.vidrala.com		
				Dibujado / Des : AMOLANO		CAD: 8302-3prt		
				Fecha / Date: 19/01/2015		Anula / Annuls: 8302-2		
				Escala / Escate: 1/1		N° Plano: Drawing N°: 8302-3		
				Retornable / Refillable NO		<input checked="" type="checkbox"/>		
				Modelo: Code: 1277/085		12 PAR		