

# 16 PAR PLUS

## Caratteristiche del prodotto

<b>Codice</b>	2278/363
<b>Capacità</b>	467 ml
<b>Imboccatura</b>	TWIST OFF 63
<b>Colori</b>	
<b>Peso</b>	260 gr
<b>Altezza Totale</b>	169.50 mm
<b>Diametro</b>	67.10 mm
<b>Pallet</b>	3.179 Unitá





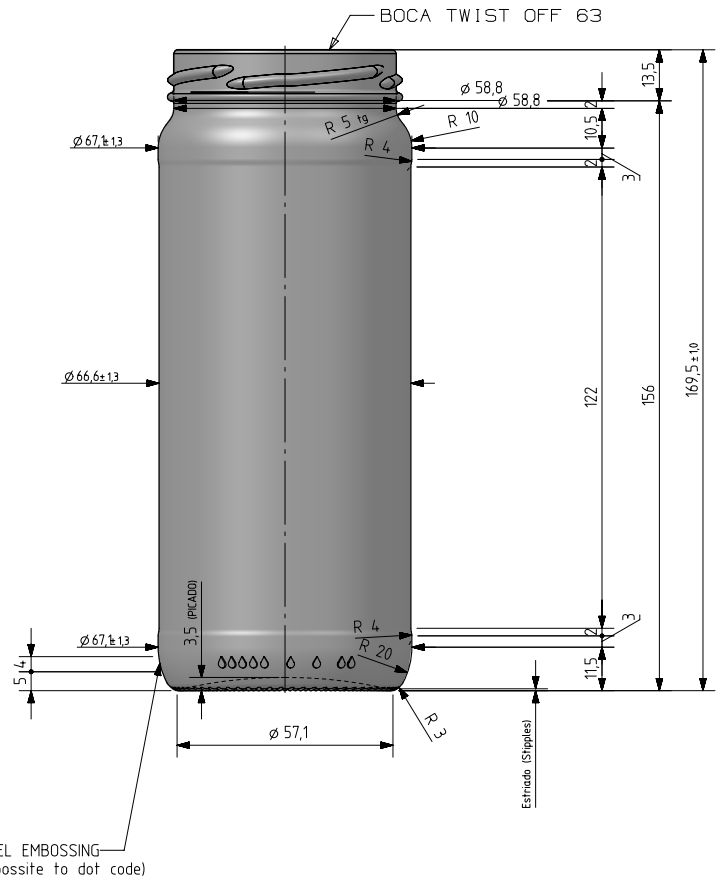

VISTA FRONTAL  
(FRONT VIEW)

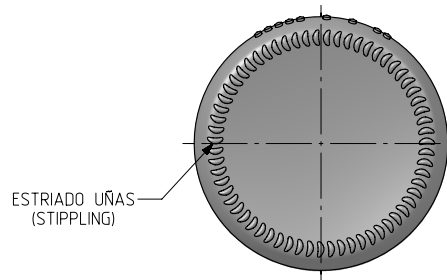

VISTA TRASERA  
(BACK VIEW)



VISTA DEL FONDO  
(BOTTOM VIEW)

				Peso aprox / Weight approx	255 gr	 <p>Product Design Office www.vidrala.com</p>
				Capacidad N. llenado / Fillpoint Capacity	467 cc ± aprox a 0 mm	
				Capacidad a verter / Brimfull Capacity	467 cc ± 10	
				Cámara expansión / Vacuity	0 % 0 cc	
				Recipiente medida / Meas cap	NO	
2	Geometría hombro y peso	14-09-18	AEA	Angulo de volcado / Tilt angle	23,4°	Dibujado / Des : AETxebarria CAD: 7597-2.prt
1	Geometría	10-09-18	AEA	Carbonatación / Gas vol	0,0 Vol CO2 máx	Fecha / Date: 03-07-18 Anula / Annuls:
Rev	Modificación / Modification	Fecha/Date	Firma/Sign	Presión larga duración / Long Term pressure: 0 Bar Max	Páster: SI	Escala / Scale: 1:1 N° Plano: 7597-2
<small>Este plano es propiedad de Vidrala, no puede ser reproducido ni comunicado sin nuestro permiso. Las cotas no toleradas son aproximadas. Specification agreements are based on tolerated dimensions only. Do not scale drawing, copyright reserved. Not to be copied in whole or part without written permission from vidrala. All dimensions are in millimeters.</small>				Resistencia. choque térmico / Thermal Shock Max:	42 °C	Modelo: 2278/363 16 PAR PLUS