

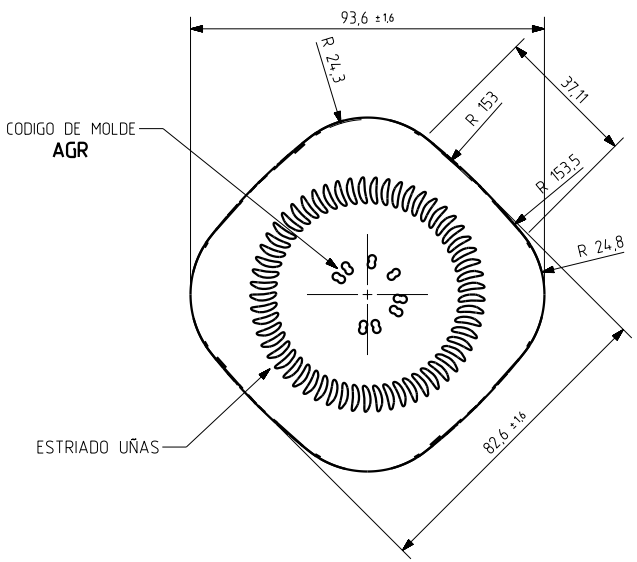

# HUILE 1 L

## Caractéristiques du produit

<b>Code</b>	1972/68A
<b>Capacité</b>	1000 ml
<b>Bague</b>	BERICAP 31/20
<b>Couleurs</b>	
<b>Poids</b>	430 gr
<b>Hauteur totale</b>	252.50 mm
<b>Diamètre</b>	82.60 mm
<b>Palette</b>	1.344 Unités

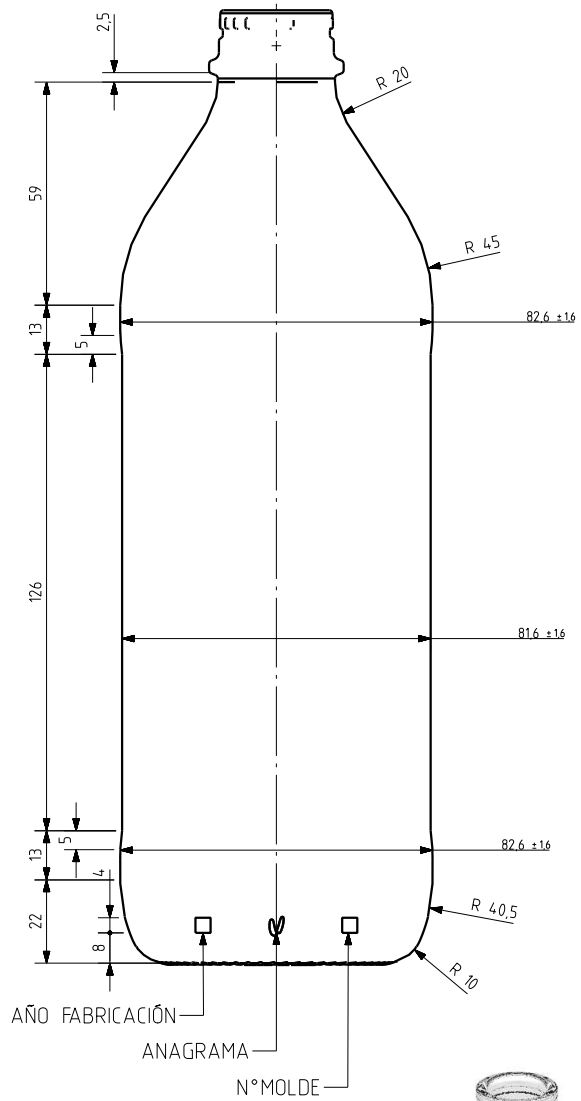
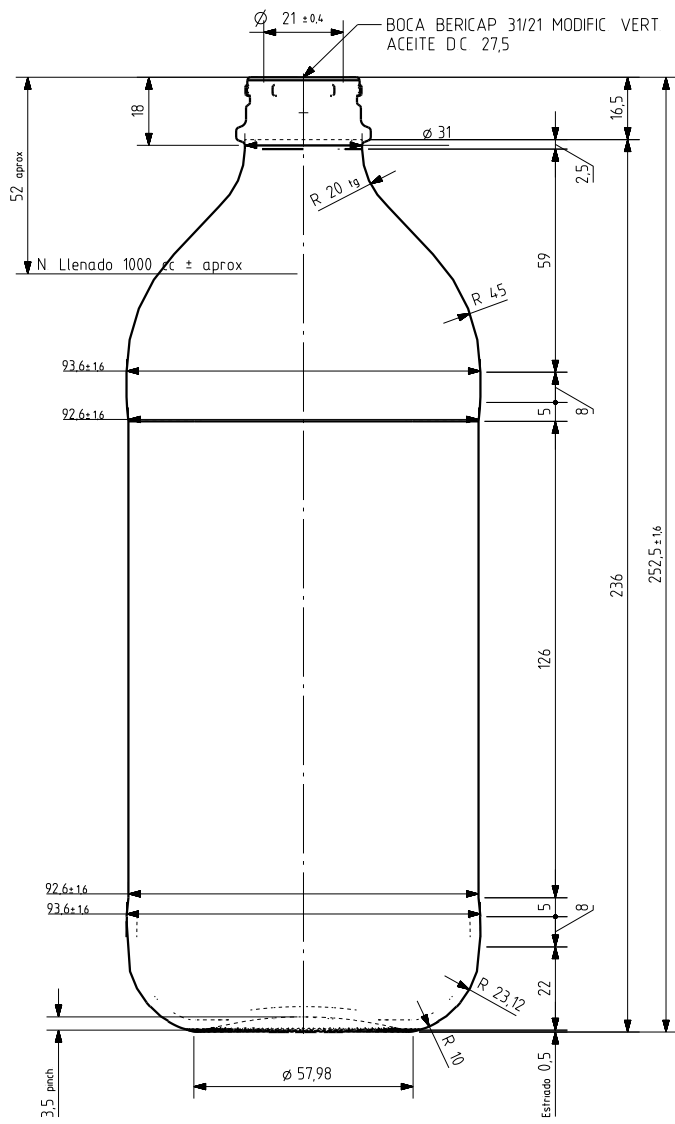



				Peso aprox / Weight approx	4,30 gr		Product Design Office www.vidrala.com		
				Capacidad N llenado / Fillpoint Capacity	1000 cc± aprox a 52,0 mm				
7	Se actualiza nivel de llenado	05/04/13	AMC	Capacidad a verter / Brimfull Capacity	1055,0cc± 10,6	Dibujado / Des	A MOLANO	CAD	6008-7prt
6	Modificación del perfil	03/04/13	AMC	Cámara expansión / Expansion Chamber	5,5 %	Fecha / Date	7-12-2012	Anula / Annuls	6008-6
5	Modificación de perfil	14/02/13	AMC	Recipiente medida / Meas cap	NO	Escala / Escala	11	N° Plano	6008-7
4	Modificación en perfil	05/12/12	AMC	Angulo de volcado / Tilt angle	16,9°	Retornable / Refillable	NO	Drawing N°	78,4%
Rev	Modificación / Modification	Fecha/Date	Firma/Sign	Carbonatación / Gas vol	0,0 Vol CO2 máx	Modelo	ACEITE 1L		
Este plano es propiedad de Vidrala, no puede ser reproducido ni comunicado sin nuestro permiso. Los datos no tolerados son aproximados. Especification agreements are based on toleranced dimensions only. Do not scale drawing, copyright reserved. Not to be copied in whole or part without written permission from Vidrala. All dimensions are in millimeters.				Presión int max (20°) / Max Pressure (20°)	0,00 Bar	Code	1972/68A		
				Resistencia choque térmico / Thermal Shock Max	42 °C				