

BD RESERVA 75 CL

Caratteristiche del prodotto

Codice	4488/242
Capacità	750 ml
Imboccatura	CORCHO CETIE
Colori	
Peso	535 gr
Altezza Totale	300.00 mm
Diametro	77.00 mm
Pallet	1.561 Unitá



Nº de modelo Nº de molde

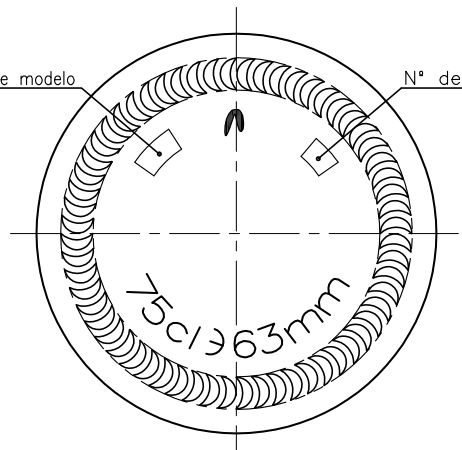

FUNDO

Este plano es propiedad de Vidrala y no puede ser reproducido ni comunicado sin nuestro permiso.
Las cotas no toleradas son aproximadas.
Specification agreements are based on toleranced dimensions only.
Do not scale drawing, copyright reserved.
All dimensions are in millimeters.

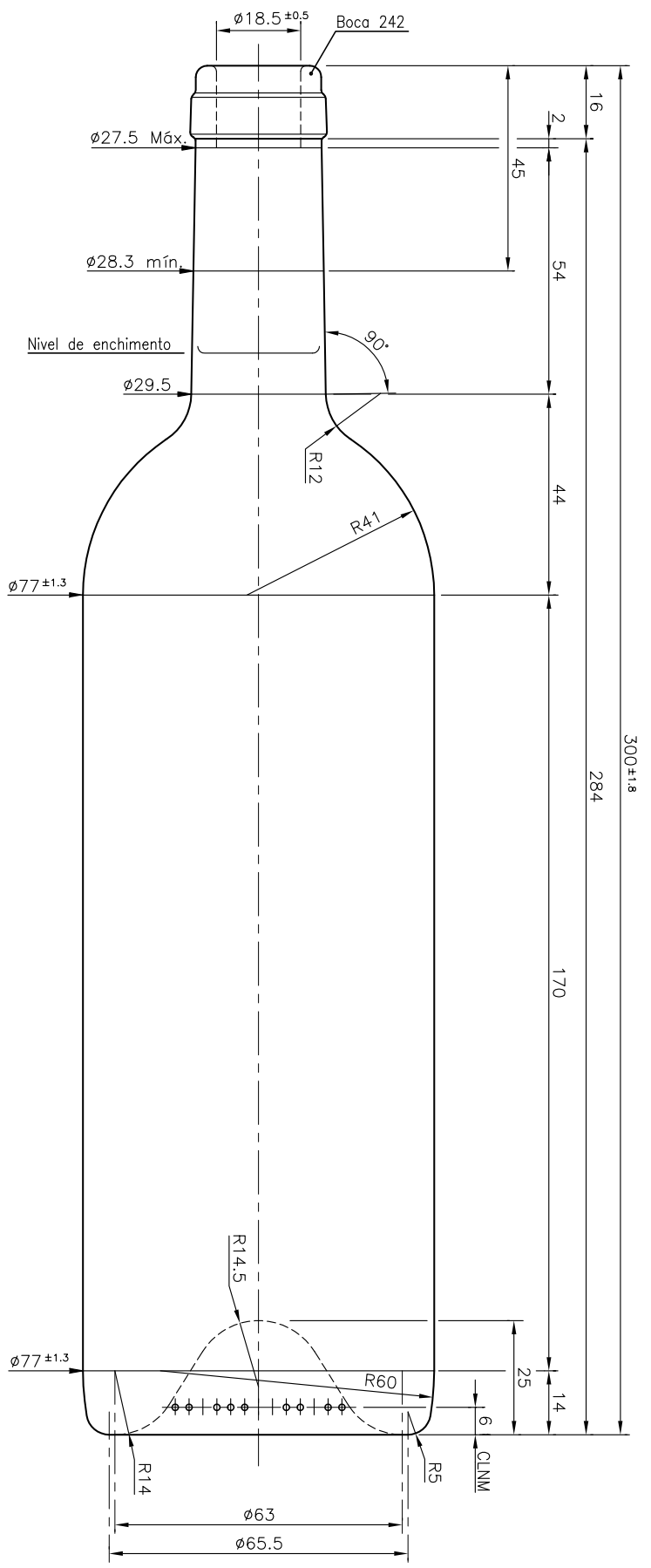

Rev.	Modificación / Modification	Fecha/Date	Firma/Sign

Peso aprox. / Weight approx	535 gr
Capacidad N. llenado / Fillpoint Capacity	750 cc ± 10 ø 63 mm
Capacidad a verter / Brimfull Capacity	767 cc ± 10
Cámara de expansión / Vacuity	2.3 % 17 cc
Recipiente medida / Meas cap	SI
Angulo de volcado / Tilt angle	.. °
Carbonatación / Gas vol	.. VolCO2 máx
Presión larga duración / Long Term pressure	.. Bar Max Páster ...
Resistencia choque térmico / Thermal Shock Max	42 °C

Rev.	Modificación / Modification	Fecha/Date	Firma/Sign

Modelo Code	4488/242	BD RESERVA 75 CL
Dibujado / Des	C. Sintra	CAO 27133(4488(242)).dwg
Fecha / Date	19-04-18	Anula / Annuls N°26421/20
Escala / Scale	1:1	Nº Plano Drawing N° 27133
Retornable / Returnable	NO	



 Product Design Office
 www.vidrala.com